

ACCESSORIES

ROTARY INDEX TABLE



Figure not binding.
Subject to technical alterations.



Increase of your pad printing machine utilisation

4 basic models with and without PLC control

Can be attached at any time later, thanks to modular design

An easy way for an affordable semi-automation

60 YEARS
1956-2016

ORIGINAL

TAMPOPRINT

Pad Printing Machines
ALFALAS® Laser Systems
Automations

Your standard pad printing machine will become a semi-automatic or a fully automatic machine. By attaching our rotary index table to your pad printing machine the capacity in pieces per hour and your comfort will be increased.

Accurate positioning of your print image / marking.

The high-quality rotary index table with a registration accuracy of +/- 0,032 mm allow a precise positioning of your print.

Supplementary equipments can be selected, they run parallel to the printing process (PLC version).

Automation units such as:

- ✓ automatic discharge
- ✓ automatic infeed
- ✓ fully automatic feeding units
- ✓ drying station

- ✓ can be mounted to a standard pad printing machine
- ✓ can be mounted to a laser marking unit

Application-specific units such as:

- ✓ pretreatment station
- ✓ after-treatment station
- ✓ air nozzles
- ✓ ink residue pick-up system
- ✓ thinner metering unit
- ✓ ionisation unit



Technical data:

Rotary Index Table	T2	T4	150 T2 + PLC	150 T4 + PLC	
Item No.	02 00 77	02 00 93	02 01 50	02 01 51	
Table	Ø mm	500	500	500	
Pitch	2x 180°	4x 90°	2x 180°	4x 90°	
Workpiece carrier possible	2	4	2	4	
Weight/station	max. kg	1,4	4	3,5	2,7
Indexing time	Sek.	1,14	1,02	1,18	0,68
Repeat accuracy	Ø 400 mm	+/- 0,042	+/- 0,042	+/- 0,032	+/- 0,032
Drive	electromechanical	electromechanical	electromechanical	electromechanical	
Control	Control relay EASY 620	Control relay EASY 620	VIPA, S7 compatible	VIPA, S7 compatible	
Control voltage	V/DC	24	24	24	
Power supply motor	230V/1/N/PE	230V/1/N/PE	230V/1/N/PE	230V/1/N/PE	
Power frequency	Hz	50-60	50-60	50-60	
Connected load	kW	0,1	0,1	0,1	
Dim. of rotary index table approx. mm	W 600 x H 145 x D 643	W 600 x H 145 x D 643	*W 700 x H 1.039 x D 627	*W 700 x H 1.039 x D 627	
Dimensions of control cabinet mm	W 380 x H 380 x D 210	W 380 x H 380 x D 210	W 500 x H 500 x D 210	W 500 x H 500 x D 210	
Weight	kg	35	35	79	

Special version upon request

* Dimensions with protective enclosure

Scope of supplies:

- ✓ Base plate
- ✓ Drive
- ✓ Control cabinet
- ✓ Operator panel
- ✓ Two-hand release
- ✓ Index table
- ✓ Pressure support

Options:

- ✓ Installation (on site TAMPOPRINT®)
- ✓ Jigs
- ✓ Light barrier left/right**
- ✓ Protective enclosure mounted on base plate with plexiglass left/right
- ✓ Base frame made of profile

** only for 150 T2 + PLC / 150 T4 + PLC

Rotary Index Table T2

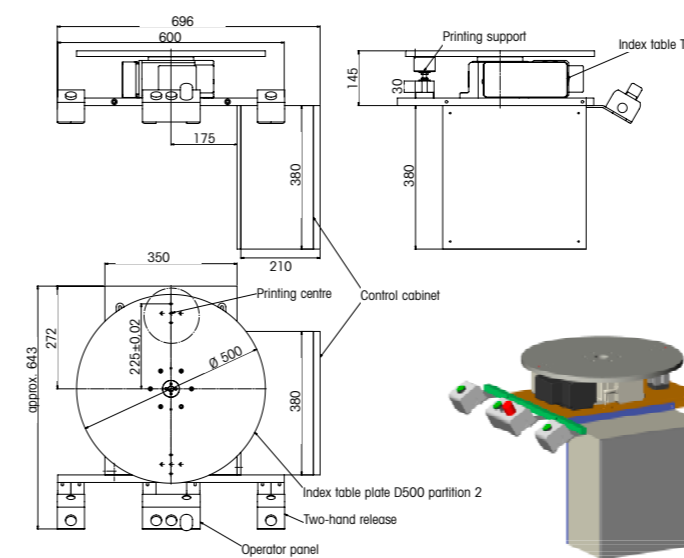

Rotary Index Table T4

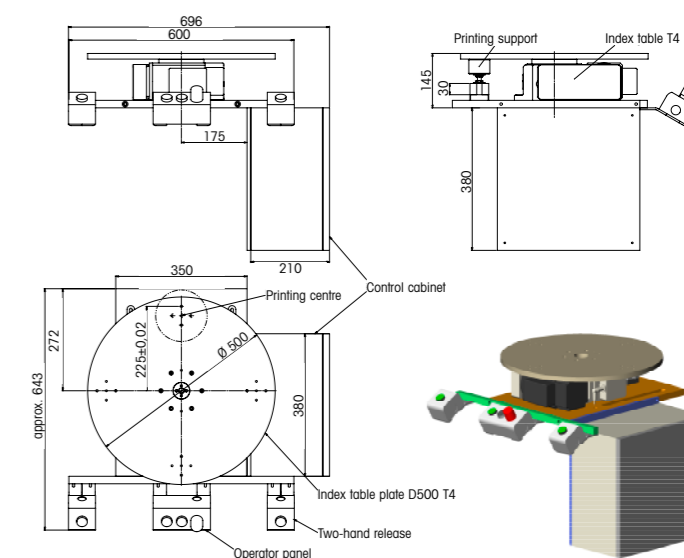

Rotary Index Table 150 T2 + PLC

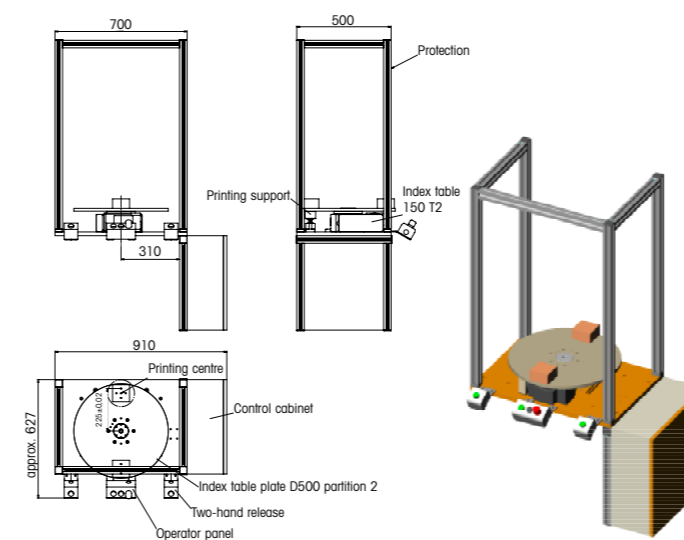

Rotary Index Table 150 T4 + PLC

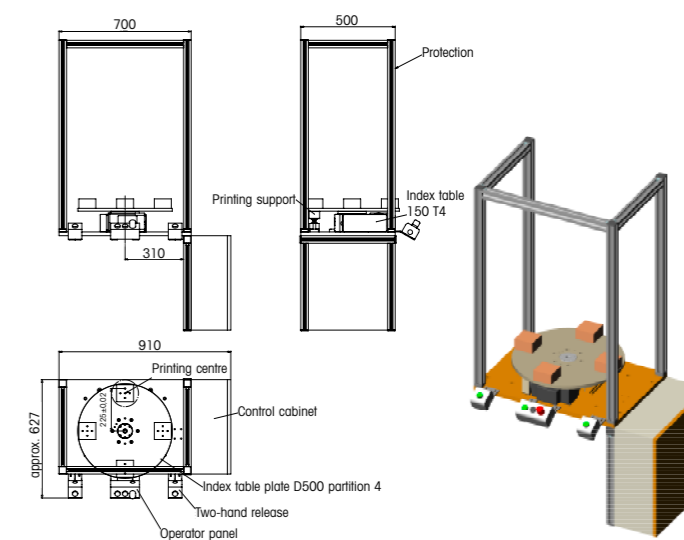

Rotary Index Table 150 T2 + PLC with option light curtain

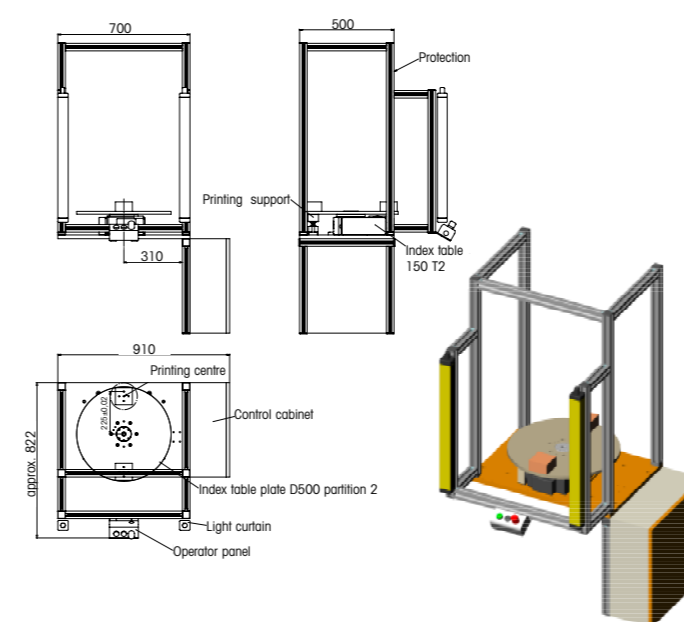

Rotary Index Table 150 T4 + PLC with option light curtain

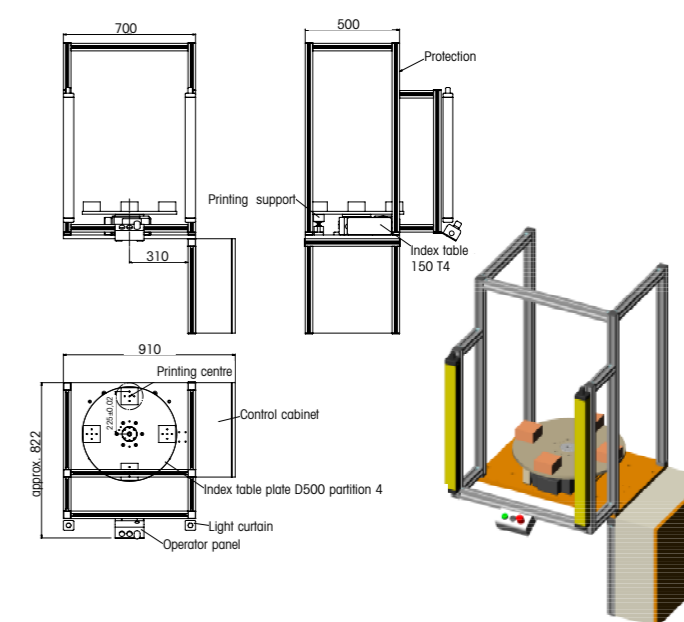

Overview of the versions:

150 T2 + PLC



T2



Technical Description:

The modular design of the index table with a base plate allows an installation at any time later. For this purpose an angle table or an aluminium base frame are necessary. Unless already included in the scope of supply of your standard pad printing machine, also this option can be installed at any time later.

The T2 and T4 index tables can be supplied with partition 2 (2x 180°) or partition 4 (4x 90°) and can be fitted with your jigs.

Thanks to their compatible control, the 150 T2 and 150 T4 offer the additional possibility to attach further options such as pretreatment and drying stations, vacuum distributor, parts discharge etc.

150 T4 + PLC



T4



Contact:

Accessories and spare parts

Fax: +49 7150 928-434

mailto: vkz@tampoprint.de



TAMPOPRINT® AG

Lingwiesenstraße 1

70825 Korntal-Münchingen, GERMANY

☎ +49 7150 928-0

Fax: +49 7150 928-400

E-Mail: info@tampoprint.de

Ventes et Affaires Françaises

☎ +49 7150 928-144

Fax: +49 7150 928-432

E-Mail: ventes@tampoprint.de

http: www.tampoprint.de

TAMPOPRINT® INTERNATIONAL CORP.

1400 26th Street, Vero Beach, FL 32960, USA

☎ +1 772 778-8896, 800 810-8896

Fax: +1 772 778-8289

E-Mail: sales@tampoprint.com

http: www.tampoprint.com

TAMPOPRINT® IBERIA S.A.U.

Polígono Industrial Martorelles,

C/ Sant Martí, s/n (entre Gorgs y Mogent)

08107 Martorelles (Barcelona), SPAIN

☎ +34 93 2327161

Fax: +34 93 2471500

E-Mail: tampoprint@tampoprint.es

http: www.tampoprint.es

ORIGINAL

TAMPOPRINT®

The reproduction of trademarks and brands used in this brochure, even if not explicitly expressed, does not justify the assumption that such names or symbols may be considered as free as defined by the Trademark Act and may therefore freely be used. The rights are the property of the respective owner.

TAMPOPRINT products are permanently updated to keep pace with the latest technological developments. For this reason, figures and descriptions are non-binding. Manufactured according to EC Directive 98/37/EC.

Subject to alterations! ©Copyright